



Low Ohm Metal Strip Current Sensor

CSE Series

1. Features

- ◆ Ideal for all type of current sensing and pulse applications.
- ◆ Extremely low resistance values.
- ◆ All welded construction.
- ◆ Alloy Resistive element.
- ◆ Very low inductance.
- ◆ Excellent frequency response.
- ◆ Low Thermal-EMF.

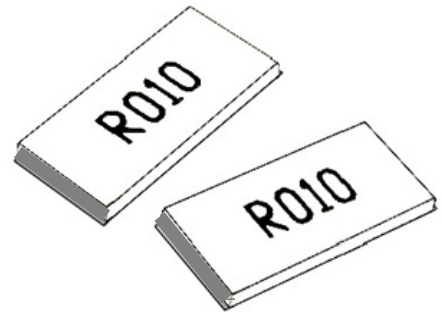

2. Applications

- ◆ Adapter
- ◆ Power supply
- ◆ Battery pack
- ◆ Battery charger
- ◆ DC-DC converter
- ◆ Instruments,
- ◆ LED Power supply
- ◆ Power amplifiers

3. Part code system

C	S	E	N	1	6	3	2	1	R	0	1	0	0	J	5
(1)			(2)				(3)	(4)					(5)	(6)	(7)

(1) Product code

(2) Internal code

(3) Dimension code (Unit = mm)

1632 = W:1.6 / L:3.2; 2550 = W:2.5 / L:5.0; 3216 = W:3.2 / L:1.6
 5025 = W:5.0 / L:2.5; 6432 = W:6.4 / L:3.2

(4) Power rating

H = 0.5W; 1 = 1W; A = 1.5W; 2 = 2W; 3 = 3W.

(5) Resistance value

Ex: R0050= 5 mΩ; R0100 = 10mΩ; R0200 = 20mΩ; R1000 = 100mΩ;

(6) Tolerance

F = ±1.0%; G = ±2.0%; H = ±3.0%; J=±5%;

(7) Packing code

Taping, 5 = 5000pcs/reel; Taping, 4= 4000pcs/reel; Bulk = B.



Low Ohm Metal Strip Current Sensor CSE Series

4. Technical specifications

4.1 Operating temperature : -55 ~ 170°C

4.2 Electrical Characteristics

Rated Power at 70°C (W)	Resistance (mΩ)	Max Rated Voltage (V)	Peak Current (A) within 10ms	TCR(p.p.m)	Insulation Resistance	Ambient Temp.
1632 0.5/1.0	5 ~ 9 10 ~ 14 15 ~ 100	$\sqrt{P \cdot R}$	35	200 (5mΩ) 70 (10mΩ) 40 (Over 10mΩ)	>100MΩ	70°C
3216 1.0/2.0	5 ~ 9 10 ~ 14 15 ~ 50	$\sqrt{P \cdot R}$	65	200 (5mΩ) 70 (10mΩ) 40 (Over 10mΩ)	>100MΩ	70°C
2550 1.5	5 ~ 9, 10 ~ 300	$\sqrt{P \cdot R}$	60	70 (below10mΩ) 50 (over 10mΩ)	>100MΩ	70°C
5025 1.5/2.0	5 ~ 9, 10 ~ 100	$\sqrt{P \cdot R}$	75	70 (below10mΩ) 50 (over 10mΩ)	>100MΩ	70°C
3264 2.0	3 ~ 4 5 ~ 9 10 ~ 300	$\sqrt{P \cdot R}$	75	200 (5mΩ) 70 (10mΩ) 40 (Over 10mΩ)	>100MΩ	70°C
6432 2.5/3.0	3 ~ 4 5 ~ 9 10 ~ 200	$\sqrt{P \cdot R}$	120	200 (5mΩ) 70 (10mΩ) 40 (Over 10mΩ)	>100MΩ	70°C

Rated voltage :

Resistors shall have a rated direct-current (DC) continuous working voltage or approximate sine-wave root-mean-square (RMS) alternating-current (AC) continuous working voltage at commercial-line frequency and waveform corresponding to the power rating as determined from the following formula:

$$E = \sqrt{P \cdot R}$$

E: Rated voltage [V]

P: Rated Power [W]

R: Nominal resistance [Ω]



Low Ohm Metal Strip Current Sensor CSE Series

4.3 Typical De-rating Curve

Power rating is based on continuous full load operation at rated ambient temperature of 70°C. For resistors operated at ambient temp. in excess of 70°C, the max. load shall be derated in accordance with the following curve.

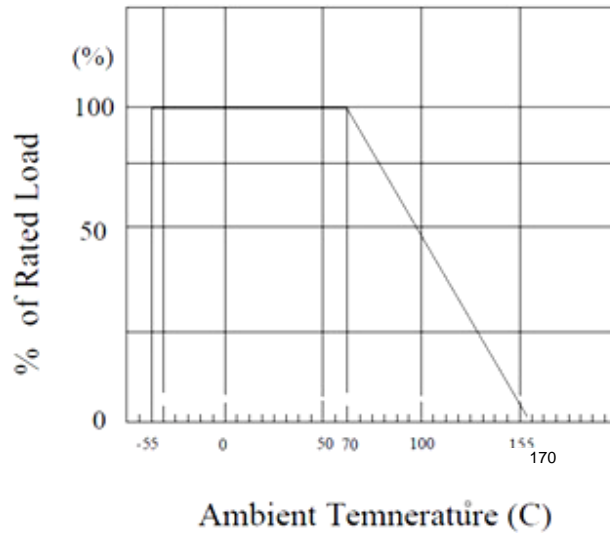

4.4 Measuring criteria : 4 line measurement.

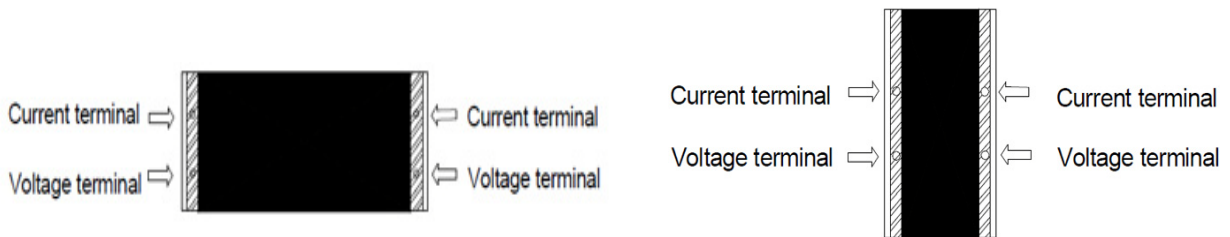

5. Test method and performance

5.1 Electrical characteristics

Test	Specification	Test condition
Resistance	Within tolerance	@25°C
Working temperature	Within tolerance	-55°C ~ +170°C
Short Time Overload	±(0.5%+0.5mΩ) IEC60115-1 4.13	2.5 x rated power for 5 seconds
Load Life at 70°C	±(1%+0.5mΩ) IEC60115-1 4.25	Applying the rated voltage cycle with 90min on and 30min off at 70±2°C. Test cycle repeats 1000Hrs.
Moisture Load Life (60°C、90%RH)	±(0.5%+0.5mΩ) IEC60115-1 4.25	Applying the rated voltage cycle on the condition of on 90min and off 30min with 60±2°C temperature and 90% humidity. Test cycle repeats for 1000Hrs.



Low Ohm Metal Strip Current Sensor CSE Series

5.2 Mechanical characteristics

Test	Specification	Test condition
Resistance to Solder Heat	$\pm(0.5\%+0.5m\Omega)$ IEC60115-1 4.18	+ 275°C Solder, 20 \pm second
Solder ability	solder shall cover minimum of 90%. IEC60115-1 4.17	Dipped into solder at 245 \pm 5oC for 3 \pm 0.5sec.
Mechanical Shock	$\pm(0.5\%+0.5m\Omega)$ IEC60115-1 4.21	a=100G for 11ms, 5 pulses
Substrate Bending	$\pm(0.5\%+0.5m\Omega)$ IEC60115-1 4.33	Span between fulcrums : 90mm Bend Width : 2mm Test board : Glass-Epoxy Board. Thickness = 1.6mm.

5.3 Environmental characteristics

Test	Specification	Test condition
Thermal Shock	$\pm(0.5\%+0.5m\Omega)$ IEC60115-1 4.19	-55°C 30min \rightarrow R.T. 3min \rightarrow +150°C \rightarrow R.T. 3min For 100 cycles.
Low Temp Storage	$\pm(0.5\%+0.5m\Omega)$ IEC60115-1 4.25	-55°C \pm 2°C for 1000 Hrs
High Temp Exposure	$\pm(0.5\%+0.5m\Omega)$ IEC60115-1 4.25	+170°C \pm 2°C for 1000 Hrs.
Moisture Resistance	$\pm(0.5\%+0.0005\Omega)\Delta R$	Level 3 : Maximum Exposure Time to Ambient condition prior to surface 168 hours , Bake Time at 125°C 8hours

6. Product's Structure

6.1 Product's dimension

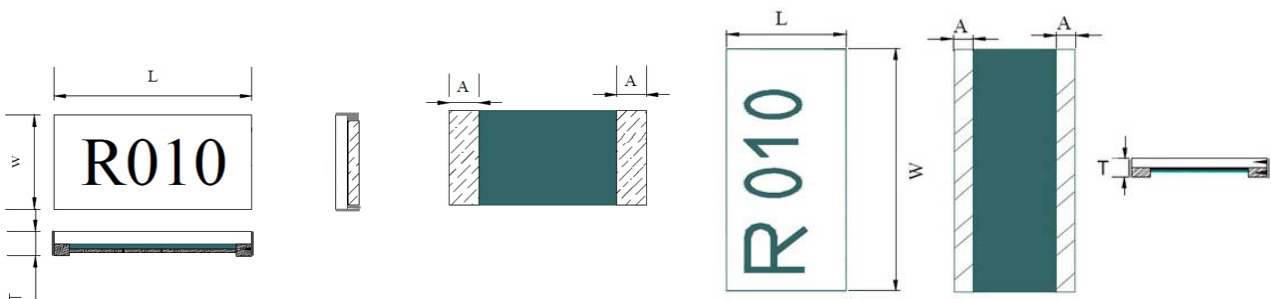



Low Ohm Metal Strip Current Sensor CSE Series

Model	W	L	T	A
CSE_1632HR__0__	1.60±0.254	3.20±0.254	0.60±0.254	0.50±0.254
CSE_2550AR0030~40__	2.50±0.20	5.00±0.20	0.60±0.15	1.80±0.20
CSE_2550AR0050~90__	2.50±0.20	5.00±0.20	0.60±0.15	1.45±0.20
CSE_2550AR010~300__	2.50±0.20	5.00±0.20	0.60±0.15	0.58±0.20
CSE_32642R__0__	3.20±0.254	6.40±0.254	0.60±0.254	1.00±0.254
CSE_32161R__0__	3.20±0.254	1.60±0.254	0.60±0.254	0.50±0.15
CSE_50252R0050~90__	5.0±0.20	2.50±0.20	0.60±0.15	0.70±0.20
CSE_50252R010~100__	5.0±0.20	2.50±0.20	0.60±0.15	0.50±0.20
CSE_64323R0050~200__	6.40±0.254	3.20±0.254	0.60±0.254	0.5±0.15

6.2 Recommended Solder Pad Layouts

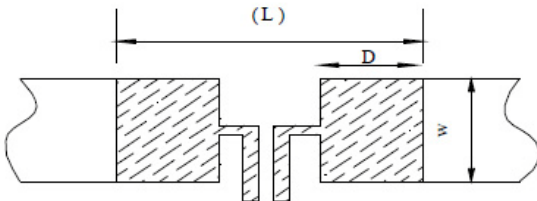

t: The thickness of the pads' metal

Size	L	W	D	t
1632	4.0mm	2.0mm	1.5mm	105u
3216	2.7mm	4.0mm	1.1mm	105u
2550 5-9m	1.40mm	2.88mm	2,65mm	105u
2550 10-300m	2.70mm	2.88mm	2,65mm	105u
5025 5-100m	12.50mm	5.75mm	2,25mm	105u
3264	8.2mm	3.8mm	2.0mm	105u
6432	4.8mm	7.5mm	1.6mm	105u

6.3 Material :

- (1) Substrate : Alumina Ceramic.
- (2) Resistive Element : Ni-Alloy
- (3) Terminal electrode : Sn / Ni / Cu
- (4) Protective coating : Flame-retardant epoxy, According to UL- 94-V0.
- (5) Marking : Flame-retardant epoxy, According to UL- 94-V0.

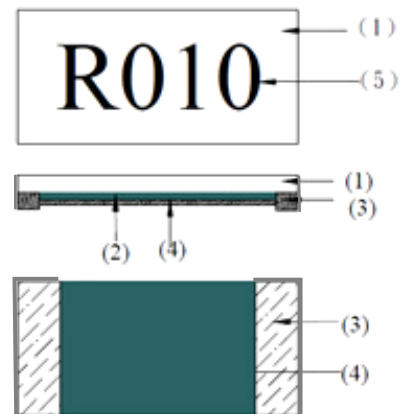



Low Ohm Metal Strip Current Sensor CSE Series

7. Soldering Suggestions

7.1 Soldering profile

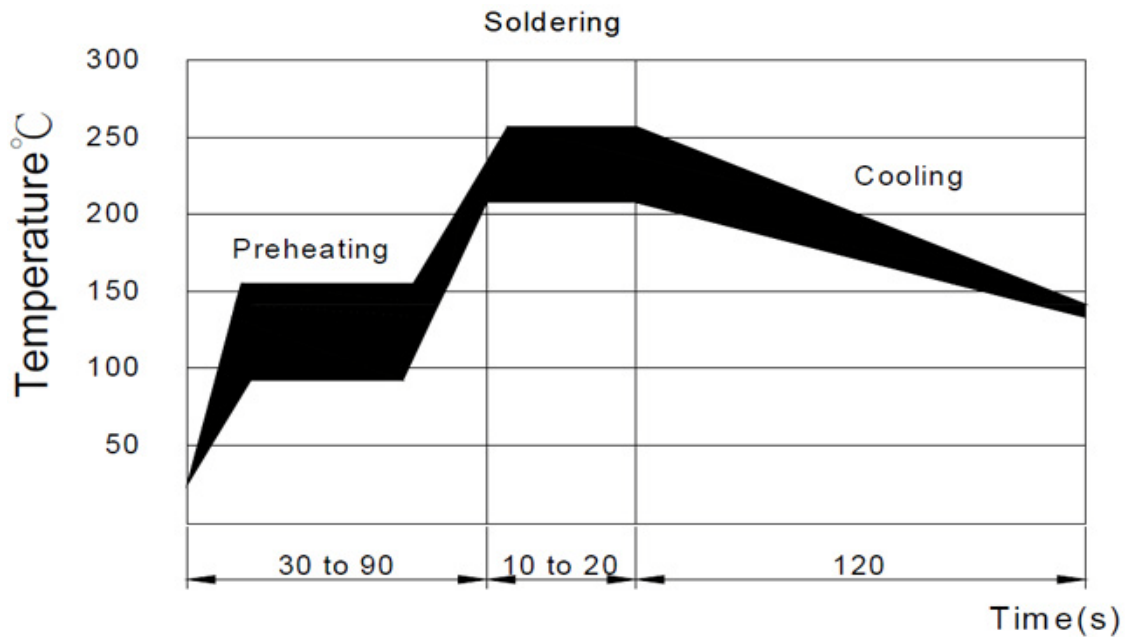

7.1.2 Soldering: min. 220°C, max. 60 sec.

7.1.3 Maximum temperature : 260±5°C, Time : 10sec.

7.2 Manual Soldering Temperature (Iron) : 350°C for 3 ~ 5 sec.

7.3 Recommended reflow methods

7.3.1 IR, vapor phase oven, hot air oven.

7.3.2 This device is not designed for wave-flow processing.

8. Marking

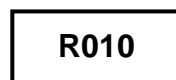

9. Packing

9.1 Reel specification

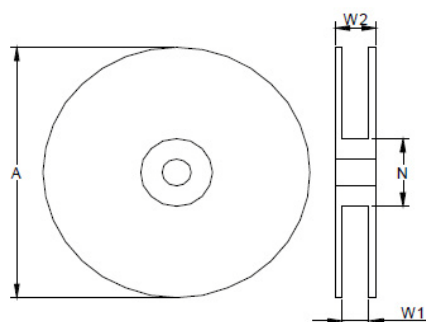

(millimeters)

A ± 5	N ± 2	W1 +1/-0	W2 Max.
178	60	8.4	18.4



Low Ohm Metal Strip Current Sensor CSE Series

9.2 Tape specification

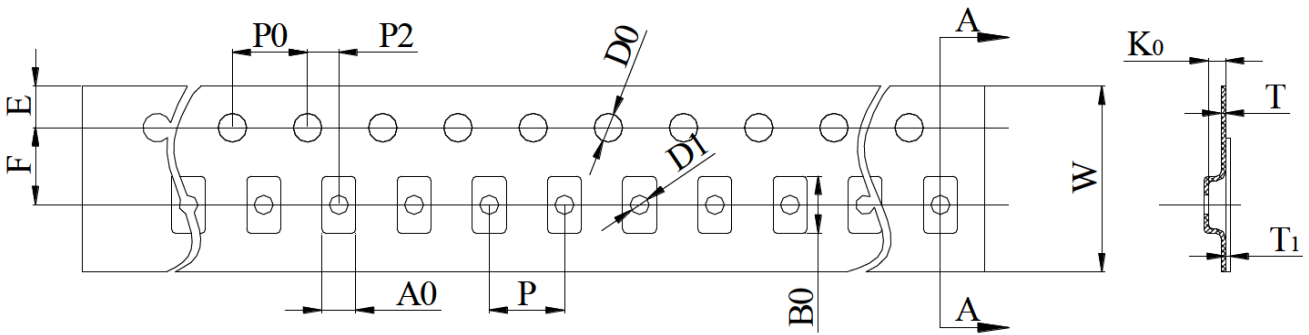

EA: mm

SIZE	A0	B0	D0	D1	P0	P1	P2	E	F	W	T	T1
1632	1.8±0.2	3.5±0.2	1.5±0.1	1.5max	4.0±0.1	4.0±0.1	2.0±0.1	1.8±0.1	3.5±0.1	12±0.1	0.2±0.1	0.2max
3216	1.8±0.2	3.5±0.2	1.5±0.1	1.5max	4.0±0.1	4.0±0.1	2.0±0.1	1.8±0.1	3.5±0.1	12±0.1	0.2±0.1	0.2max
2550	3.0±0.2	5.6±0.2	1.5±0.1	1.5max	4.0±0.1	4.0±0.1	2.0±0.1	1.8±0.1	5.5±0.1	12±0.1	0.2±0.1	0.2max
5025	3.0±0.2	5.6±0.2	1.5±0.1	1.5max	4.0±0.1	4.0±0.1	2.0±0.1	1.8±0.1	5.5±0.1	12±0.1	0.2±0.1	0.2max
3264	3.5±0.2	6.8±0.2	1.5±0.1	1.5max	4.0±0.1	4.0±0.1	2.0±0.1	1.8±0.1	5.5±0.1	12±0.1	0.2±0.1	0.2max
6432	3.5±0.2	6.8±0.2	1.5±0.1	1.5max	4.0±0.1	4.0±0.1	2.0±0.1	1.8±0.1	5.5±0.1	12±0.1	0.2±0.1	0.2max

9.3 Peeling Strength of Seal Tape

F = Peeling Strength: 0.1 - 0.7N (10 - 71gf)

